

Energy Storage LiFePO₄ Battery

User manual



Important safety instructions

Important safety instructions.

Please keep this manual for future reference.

This manual contains all the safety installation and operation instructions of the ES25.6/51.2 series energy storage LiFePO₄ battery.

Please read all instructions and precautions in the manual carefully before installation and use.

1. To avoid personal injury, users should not disassemble it by themselves, since the energy storage LiFePO₄ battery has unsafe voltage inside. If need repairs, please contact our company's professional maintenance personnel.
2. Do not install the energy storage LiFePO₄ battery in a place where children can touch.
3. Do not install the energy storage LiFePO₄ battery in harsh environments such as damp greasy, flammable, explosive, or dust accumulation.
4. When the energy storage LiFePO₄ battery is working, please do not open the box.
5. It is recommended to install a suitable fuse or circuit breaker externally.
6. After installation, check whether all line connections are tight to avoid the risk of heat accumulation due to virtual connection.
7. Wall mounted energy storage battery shall be charged with DC power supply, parallel connection with other AC power supply or different voltage and brand batteries is prohibited.

Contents

1. Basic information	3~4
2. Installation process	5
3. Installation instructions	5~10
3.1 Installation notes	5~6
3.2 Installation and wiring	6
3.3 Schematic diagram of the installation	7~9
3.4 Necessary Installation Tools	10
3.5 Personal Protective Equipment +1000 Vdc Insulated Tools	10
4. Schematic diagram of connecting	11~12
5. LED instructions	13~14
6. BMS communication settings	15~18
6.1 BMS communication and setting	15
6.2 Communication address selection specification	16
6.3 Inverter Compatibility List	17
6.4 Low Voltage Battery to inverter CAN Terminal Pin Out	17~18
6.5 Low Voltage Battery to inverter RS485 Terminal Pin Out	18~19
7. Color touch screen instructions	19~21
8. Technical parameter list	22
9. Maintenance and conservation	23
10. Warranty record card	24

1. Basic information

1.1 Product overview

ES25.6/51.2 series energy storage battery is mainly used in the field of household power storage. At the same time, it is also suitable for the internal energy storage of RV, household energy storage and temporary buildings. It adopts high-performance and long-life lithium iron phosphate battery as the basic energy storage unit, combined with advanced lithium-ion battery management system industrial design of household products and other technologies. Ensure that products have high reliability and high industrialization standards. ES25.6/51.2 series energy storage battery covers the energy demand of a single machine from the 2.56 kwh to 11.77 kwh, and the rated output voltage is 25.6V/51.2V.

ES25.6/51.2 series products have wall mounting function and can support external parallel use function, which greatly improves the convenience of use.

Through scientific and reasonable active heat dissipation. ES25.6/51.2 series energy storage battery improves the consistency of internal temperature field, prolongs service life, and enables the product to continuously output high current.

1.2 Features

- ◆ The external color touch screen is used to monitor the energy storage battery data and operating status in real time.
- ◆ The battery adopts high-performance lithium iron phosphate battery with high safety performance and long service life.
- ◆ External weak current switch reduces product power consumption and improves the safety of transportation and storage.
- ◆ With RS232/RS485/CAN communication function, it can easily communicate with the equipment with communication.
- ◆ External wireless module can be connected for remote data monitoring and corresponding control.
- ◆ The energy battery is equipped with a wall bracket to meet the installation and use of different places.
- ◆ It has multiple protection functions to protect the safety of power supply in an all-round way.
- ◆ The output is stable and can be connected to different loads within the voltage range.
- ◆ Support up to 15 independent modules for parallel use.

1.3 Function description

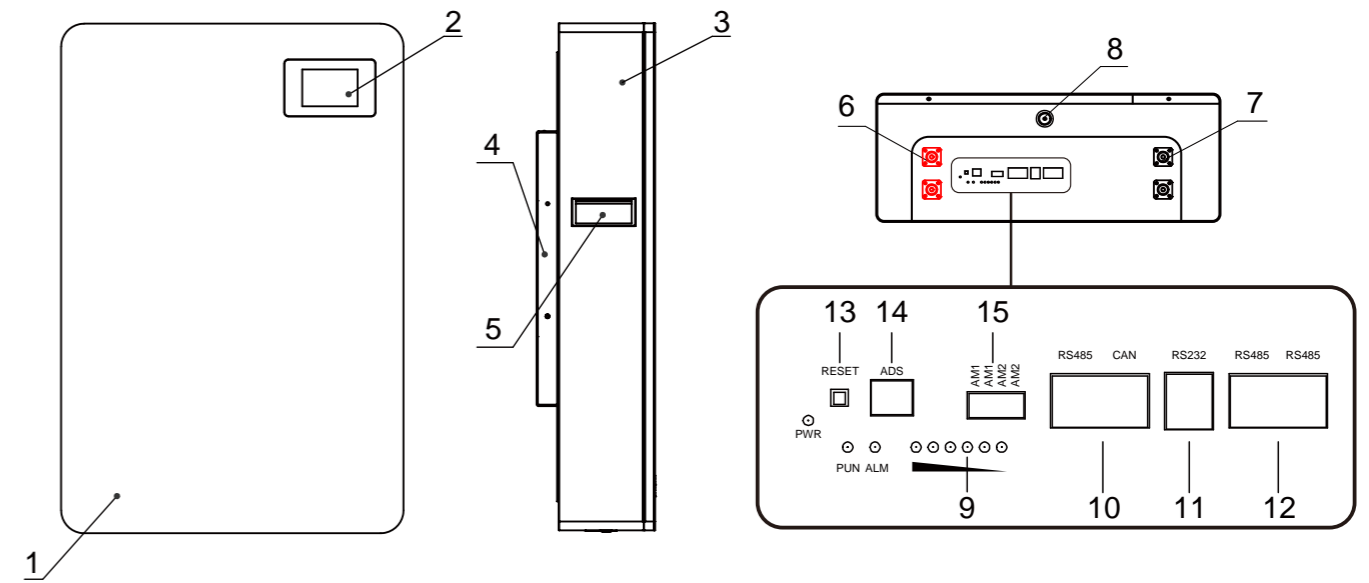

1	White face cover	2	Touch screen
3	White cabinet	4	Wall mounted bracket
5	Handle	6	M6/M8 Positive terminal (2pcs)
7	M6/M8 Negative terminal (2pcs)	8	OFF/ON

- ◆ 9 SOC Display: 6 LED indicator with each one indicates about 17% SOC (State of Charge).
- ◆ 10 "RS485/CAN" battery can communicate with the INVERTER through RS485/CAN interface so that the inverter can monitor all kinds of battery information, including battery voltage current, temperature, status, SOC, SOH etc.. The default baud rate is 9600bps.
- ◆ 11 RS232: it can monitor the single pack information by computer.
- ◆ 12 RS485/RS485: this interface is used in parallel with battery strings, the master-controlled Pack communicates with the slave-controlled Pack through the RS485 port, so that the information of all packs can be viewed through the RS485/CAN port by the master-controlled Pack. BTW, this RS485 port cannot be used for parameter setting and corresponding controlled operation.
- ◆ 13 Reset: When the PACK is in the sleep state, press this key (3-6s) and release it to activate. If the PACK is in the active state, press this key (3-6s) and release it to sleep.
- ◆ 14 When "ADS" is used for parallel use of battery packs, different packs can be distinguished by hardware address, and the hardware address of each PACK in the whole battery stack is unique, and the hardware address can be set in sequence by DIP switch, the definition of switch refer to "Instructions for Selecting Communication Address";
- ◆ 15 Dry contact AM1 normally OPEN and CLOSED during fault protection; Dry contact AM2 normally OPEN and CLOSED during low energy alarm.

2. Installation process

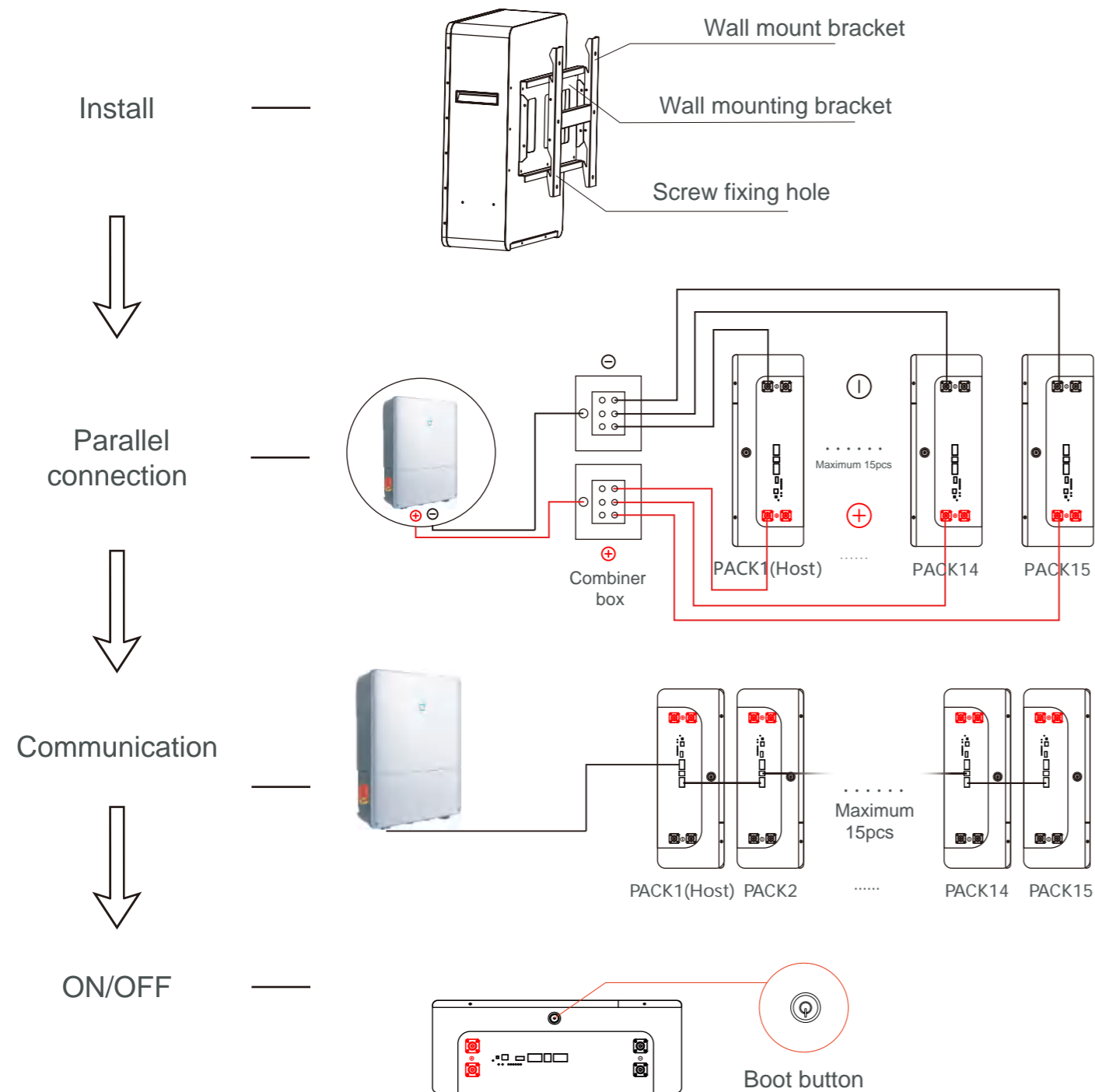

3. Installation instructions

3.1 Installation notes

Before installation, please read this manual carefully and familiarize the installation steps.

(1) Be sure to leave a certain space around for heat dissipation during installation.

- (2) Avoid sunlight direct and rainwater infiltration during outdoor installation to cause battery damage.
- (3) Do not place metal products near the place of the energy storage LiFePO₄ battery installation to prevent short circuits.
- (4) Virtual connection points and corroded wires may generate high heat, and the molten insulation layer will burn surrounding materials and even cause a fire. Therefore, it must be ensured that the connector has been tightened and the wires should be secured with cable ties to avoid loosening of the connector due to shaking during mobile applications.
- (5) After the battery switch is turned off, there is still high voltage inside the energy storage case. Please do not open or touch the internal components, and external short circuit is strictly prohibited.
- (6) Please do not install it in a harsh environment where a large amount of damp, greasy, flammable and explosive dust gathers.
- (7) It is forbidden to reverse the charging and discharging terminals of the battery, otherwise it is very easy to damage the battery or cause unpredictable risks.
- (8) When installing the battery on the wall, you must first ensure the bearing capacity of the wall and check whether the screws are installed firmly to avoid unnecessary danger.
- (9) If an injury occurs during installation or use, please seek medical attention in time.

3.2 Installation and connection

Installation and connection must comply with national and local electrical code requirements. According to the current situation, firstly, choose the corresponding wire or a wire with a larger wire diameter to avoid unnecessary troubles during use. Secondly, determine the installation location. Thirdly, when installing, please make sure to leave at least 200 mm of space at the air outlets on both sides of the energy storage battery to ensure natural convection heat dissipation.

3.3 Schematic diagram of the wall mounted installation

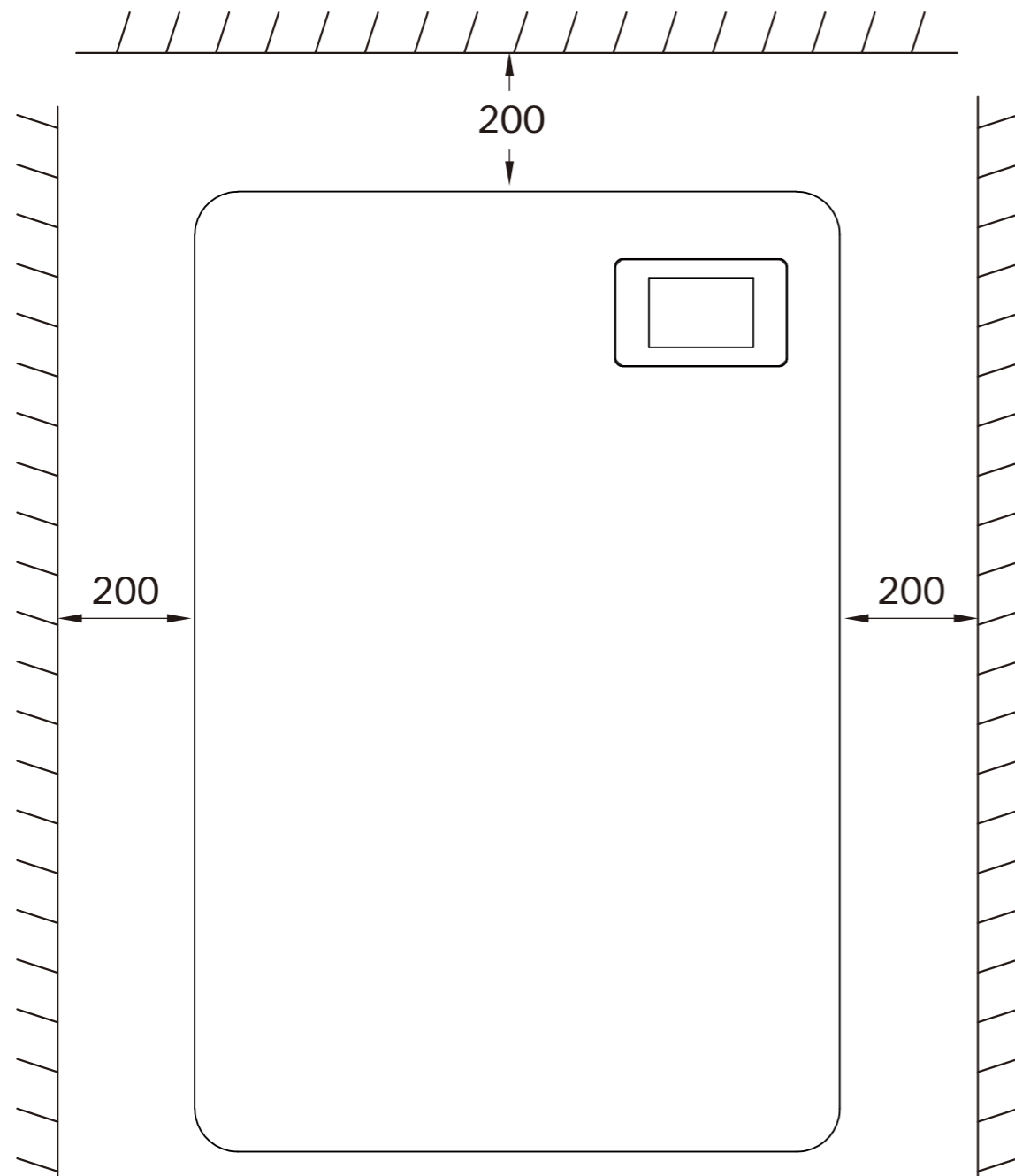

Warning: Danger of explosion! In order to avoid accidents, do not reverse connect the charging and discharging ports or short circuit, and do not install them in a closed environment. Rain proof and moisture-proof protection must be installed in the outdoor.

Attention!! The above steps can be omitted without wall mounting.

Attention!! When only one 51.2V100Ah or 25.6V230Ah battery pack is used, it is recommended to use an inverter lower than 5kw or other load lower than 5kw, and when only one 25.6V100Ah battery pack is used, it is recommended to use an inverter lower than 2.5kw or other load lower than 2.5kw.

Attention!! Before making the final DC connection, please ensure that the battery switch / DC circuit breaker is disconnected, and ensure that the positive (+) must be connected to the negative positive(+), and the negative (-) must be connected to the negative(-).

Recommended external wiring diameter and switch selection.

Model	Recommended external wiring diameter	The system is continuously current	Circuit breaker/ empty open recommended
ES51.2-100LP	25mm ²	100A	2P-125A
ES51.2-230LP	50mm ²	200A	2P-250A
ES25.6-100LP	25mm ²	100A	2P-125A
ES25.6-230LP	25mm ²	100A	2P-125A

Note: The wiring diameter is for reference only. If the distance between the load and the battery is relatively long, a larger wire can be used to reduce the line resistance and improve system performance. The above wire diameter and circuit breaker are only suggestions, please follow the actual situation to choose the appropriate wire diameter and circuit breaker.

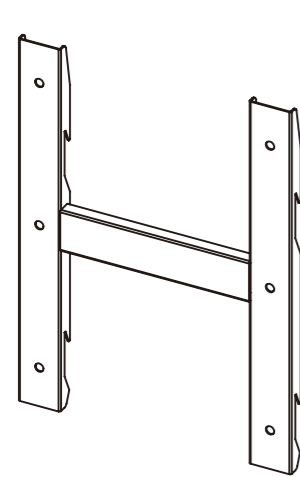

Picture 1

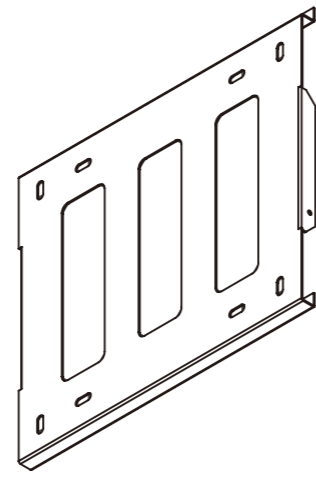

Picture 2

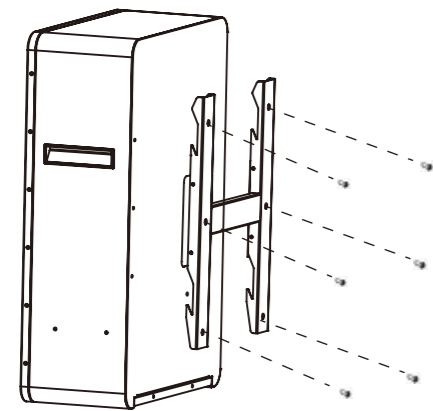

Picture 3

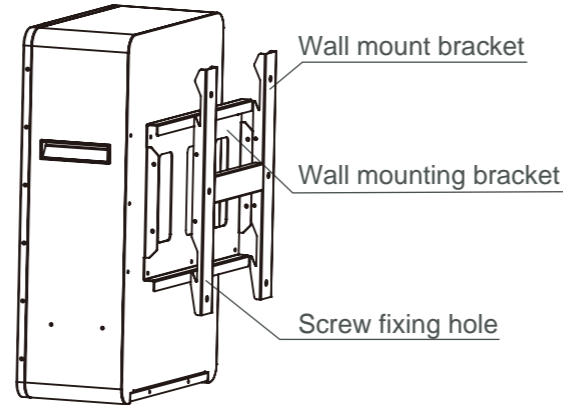

Picture 4

As shown in the pictures above:

- (1) According to the actual situation, first install the wall mounting plate with M8 expansion screw on the wall to ensure that the installation is firm (picture 1).

Note: the height of the expansion screw protruding from the wall shall be controlled within 25mm to avoid interference with the battery box during installation (Picture 2).

- (2) Fix the wall mounting bracket on the outer box of the battery with M6 screws, and ensure that the bolts are tightened with a torque of 2-3 nm (Picture 3).

3.4 Necessary Installation Tools

<p>Multimeter + Current clamp</p>	<p>Insulated Screwdriver Set</p>	<p>Insulated Allen Key Set from 2 mm to 8 mm</p>	<p>Drill+Hammer</p>
<p>Electrician Scissors</p>	<p>Insulated Torque Wrench Set</p>	<p>Lifting Strap + Mechanical Lifter</p>	<p>RS232/USB +Screw Terminal (insulated)</p>

3.5 Personal Protective Equipment +1000 Vdc Insulated Tools



4. Schematic diagram of connecting

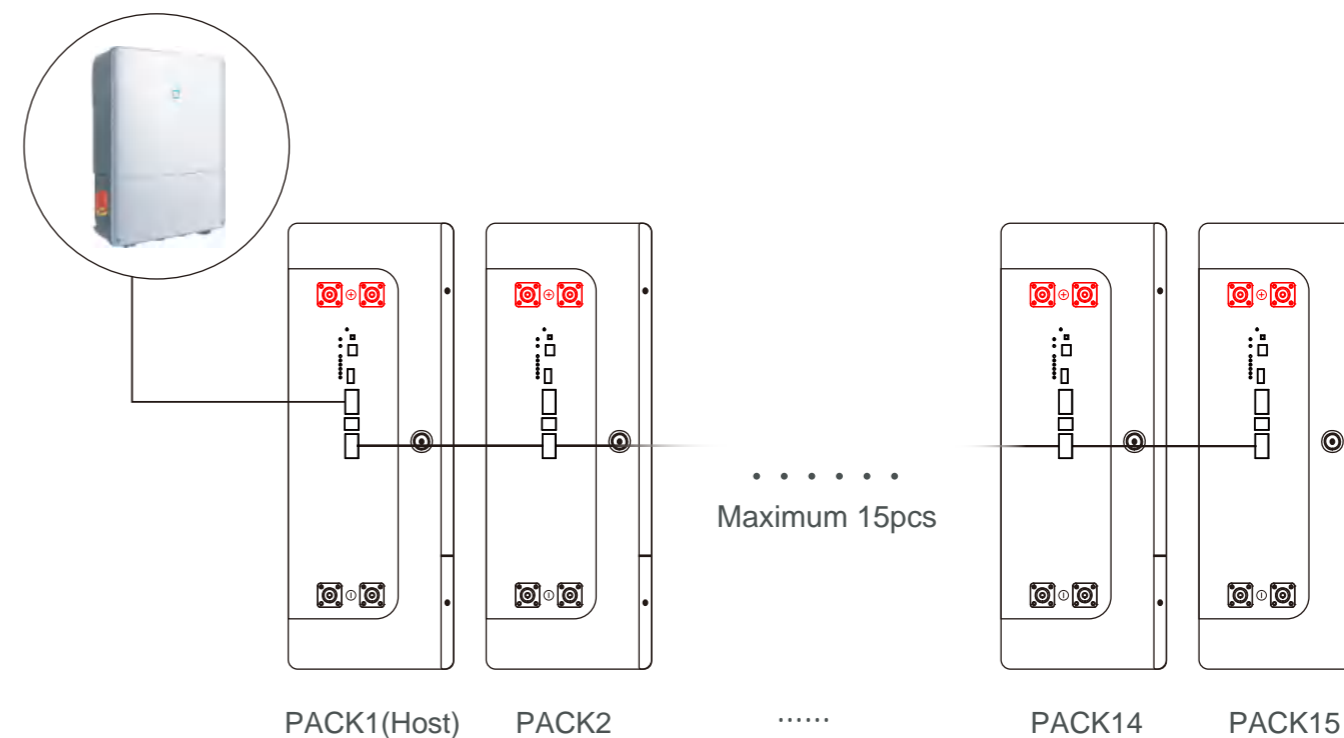
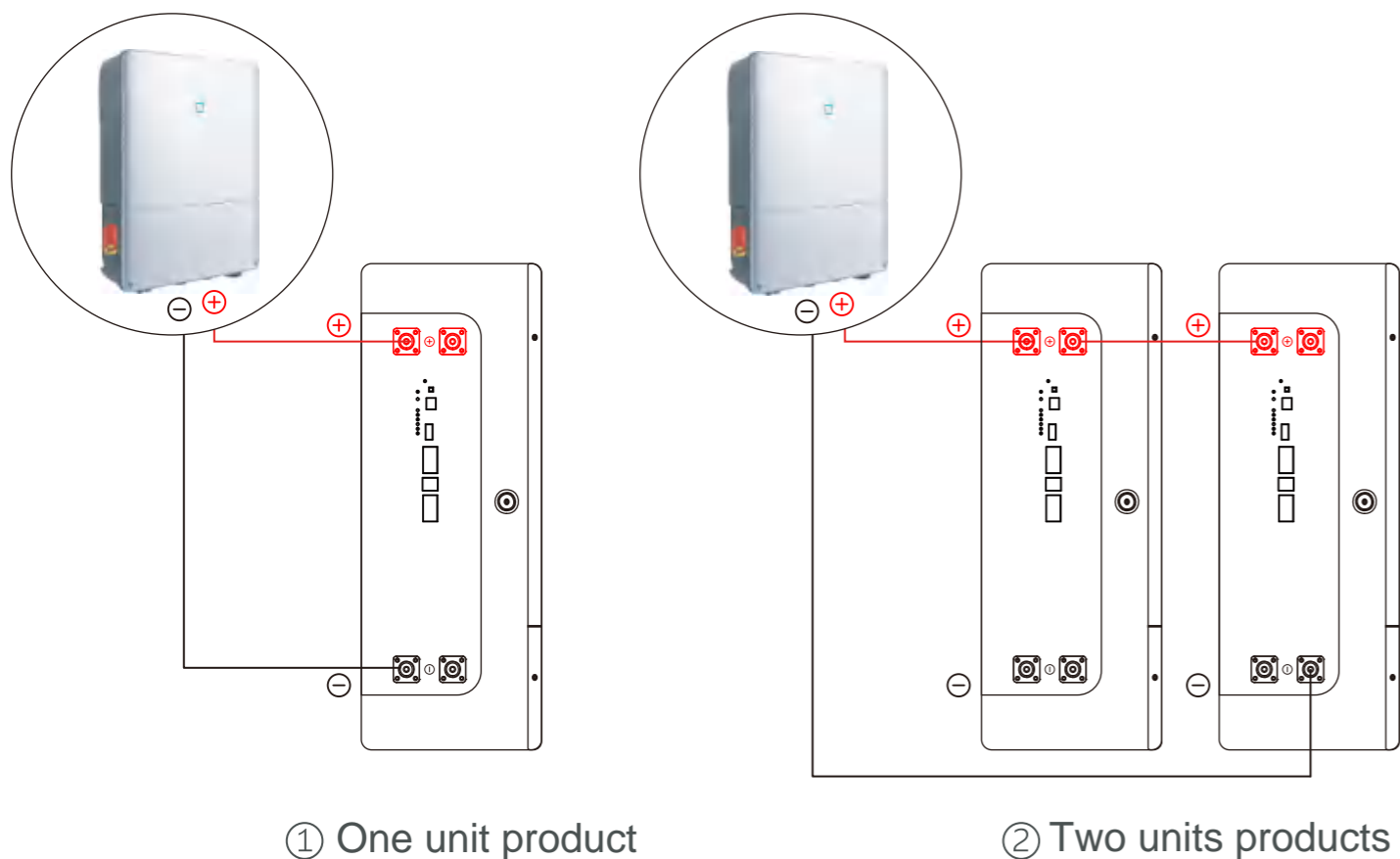

Note: 1. When the battery pack is used in parallel, it is necessary to distinguish different packs by hardware address, and the hardware address of each pack in the whole battery pack is unique.

2. It must set up a park for the host park. The inverter communicate with host pack via RS485/CAN. The hardware address can be set successively through the dial switch on the board.

3. After the battery connected to the inverter, turn on the inverter for 5 minutes before turning on the battery, to prevent the BMS being burned out by the excessive surge voltage of the inverter.

Recommended setting data of inverter:

Battery model	LiFePO4/Lithium battery			
Model	ES25.6-100LP	ES25.6-230LP	ES51.2-100LP	ES51.2-230LP
Discharge cut-off voltage	25	25	50	50
Over discharge recovery	26	26	51	51
Normal charging voltage	29.2	29.2	58.4	58.4
Overvoltage protection	29.2	29.2	58.4	58.4
Overvoltage recovery	28	28	56	56
Discharge cut-off SOC	10%			

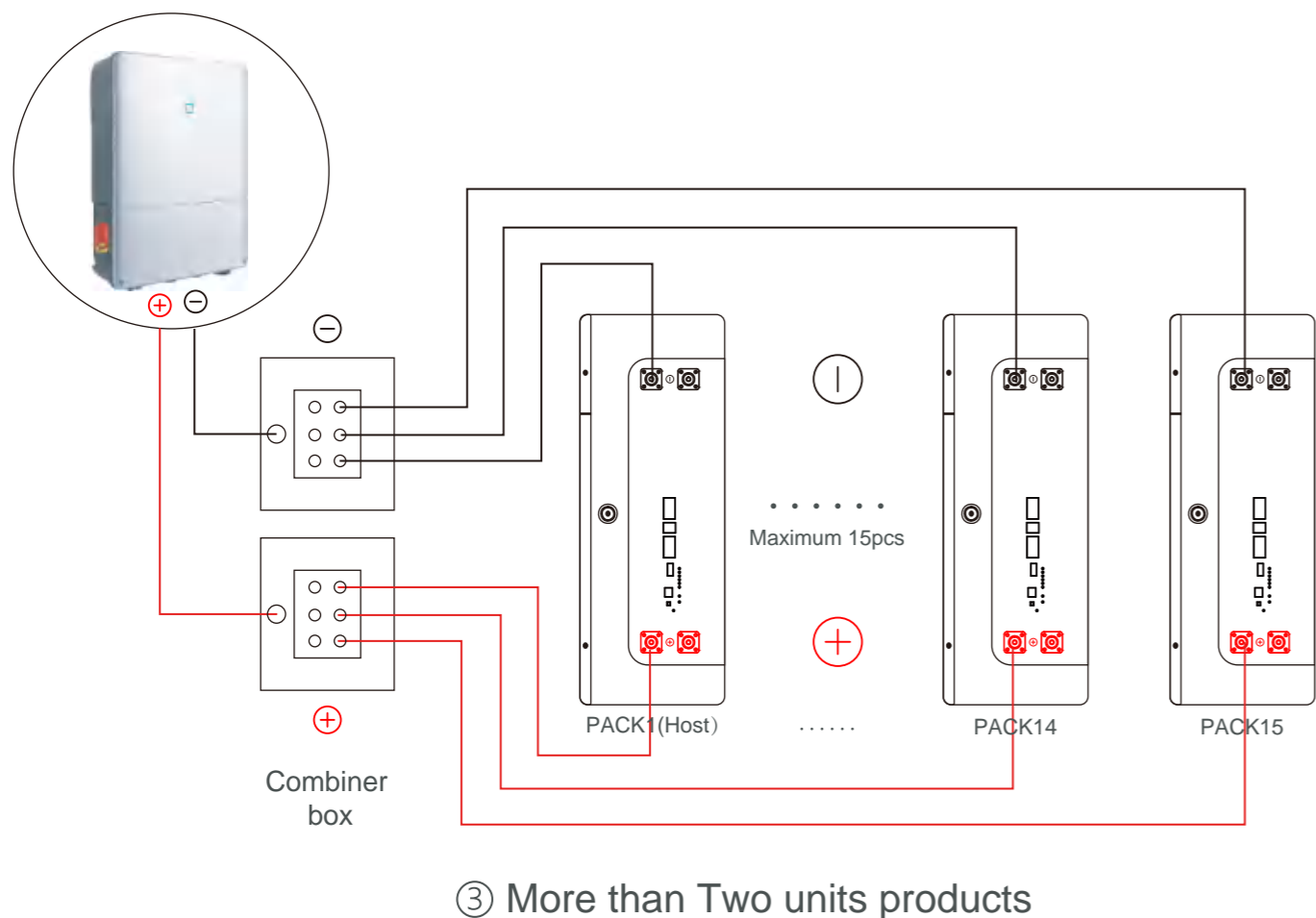

5. LED instructions

Table1 LED working status indication

State	normal/warning/protect	RUN	ALM	Battery indicator LED				illustrate
		●	●	●	●	●	●	
Shutdown	hibernate	extinguish	extinguish	extinguish	extinguish	extinguish	extinguish	annihilate
Standby	normal	flash 1	extinguish	According to the battery indicator				standby mode
	alert	flash 1	flash 3					Module low voltage
Charge	normal	Always bright	extinguish	According to the battery indicator (battery indication maximum LED flashes 2)				Maximum battery LED flashes Move (flashing 2), overcharge warning ALM does not flash during alarm
	alert	Always bright	flash 3					
	Overcharge protection	Always bright	extinguish	Always bright	Always bright	Always bright	Always bright	If there is no utility power, indicate Light goes to standby
	temperature, overcurrent, Failsafe	extinguish	Always bright	extinguish	extinguish	extinguish	extinguish	stop charging
Discharge	normal	flash 3	extinguish	According to the battery indicator				stop charging
	alert	flash 3	flash 3					
	Undervoltage protection	extinguish	extinguish	extinguish	extinguish	extinguish	extinguish	stop charging
	temperature, overcurrent, short circuit, Reverse connection, failsafe	extinguish	Always bright	extinguish	extinguish	extinguish	extinguish	stop charging
Invalid		extinguish	Always bright	extinguish	extinguish	extinguish	extinguish	Stop charging and discharging

Table2 Description of capacity indication

state		Charge						discharge					
capacity indicator		L6 ●	L5 ●	L4 ●	L3 ●	L2 ●	L1 ●	L6 ●	L5 ●	L4 ●	L3 ●	L2 ●	L1 ●
Battery (%)	0~17%	extinguish	extinguish	extinguish	extinguish	extinguish	flash 2	extinguish	extinguish	extinguish	extinguish	extinguish	constant
	18~33%	extinguish	extinguish	extinguish	extinguish	flash 2	constant	extinguish	extinguish	extinguish	extinguish	constant	constant
	34~50%	extinguish	extinguish	extinguish	flash 2	constant	constant	extinguish	extinguish	extinguish	constant	constant	constant
	51~66%	extinguish	extinguish	flash 2	constant	constant	constant	extinguish	extinguish	constant	constant	constant	constant
	67~83%	extinguish	flash 2	constant	constant	constant	constant	extinguish	constant	constant	constant	constant	constant
	84~100%	flash 2	constant	constant	constant	constant	constant	constant	constant	constant	constant	constant	constant
Running lights ●		constant						Blink (blink 3)					

Table 3 LED flashing description

flashing method	Bright	extinguish
flash 1	0.25S	3.75S
flash 2	0.5S	0.5S
flash 3	0.5S	1.5S

Remarks: The LED indicator alarm can be enabled or disabled through the host computer, and the factory default is enabled.

◆ Key Description

1. In the normal operation state, the system enters the sleep/shutdown state after 3 minutes of keyless operation.
2. In the shutdown/hibernate state, operate any button, the display will be activated, and the main status interface will be entered.
3. After the BMS is reset, the parameters and functions set by the host computer are still retained. If it is necessary to restore the initial parameters, it can be achieved through the "restore default value" of the host computer, but the relevant operation records and stored data remain unchanged (such as power, cycle times, etc.).

6. BMS communication settings

6.1 BMS communication and setting

When the load (such as inverter) needs to communicate with the battery, in order to establish normal communication with the load, BMS needs to set the following settings for each brand. The RS485/CAN communication protocols of inverters are different, but there are several RS485/CAN communication protocols inside the inverter to match the battery. When using, you can directly select the communication protocol code in the inverter for matching. If you have other problems, please consult the supplier.

Battery BMS interface pin foot definition as shown in the following figure

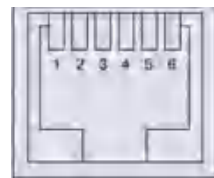

RS232
Communication interface

The battery communication interface adopts 8P8C RJ45 socket.					
RS232	PIN	2	3	4	5
	Definition	NC	TX	RX	GND

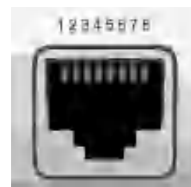

RS485
Communication interface

The battery communication interface adopts 8P8C RJ45 socket.					
RS485/ CAN	PIN	1、8	2、7	4	5
	Definition	RS485-B	RS485-A	CAN-H	CAN-L



ADS

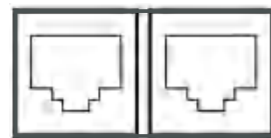

RS485 CAN



RS232

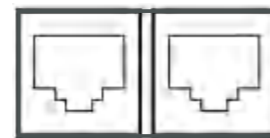

RS485 RS485

- ◆ “ADS” is used for parallel use of battery packs. PACK can be distinguished by hardware address. The definition of ADS master-slave address refers to communication address selection specification.
- ◆ “RS232” it can monitor the single pack information by computer.
- ◆ “RS485/RS485” is used in parallel for battery pack, and the main communicates with pack from the interface.
- ◆ “RS485/CAN” battery pack can communicate with the inverter through this interface.

Note: The battery default protocol is Pylon.

6.2 Communication address selection specification

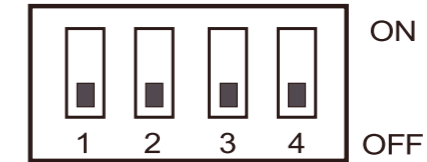

Address	Code switch position				Illustrate
	1#	2#	3#	4#	
0	OFF	OFF	OFF	OFF	Stand-alone use, no cascade
1	ON	OFF	OFF	OFF	Set to Pack 1 (Host)
2	OFF	ON	OFF	OFF	Set to Pack 2
3	ON	ON	OFF	OFF	Set to Pack 3
4	OFF	OFF	ON	OFF	Set to Pack 4
5	ON	OFF	ON	OFF	Set to Pack 5
6	OFF	ON	ON	OFF	Set to Pack 6
7	ON	ON	ON	OFF	Set to Pack 7
8	OFF	OFF	OFF	ON	Set to Pack 8
9	ON	OFF	OFF	ON	Set to Pack 9
10	OFF	ON	OFF	ON	Set to Pack 10
11	ON	ON	OFF	ON	Set to Pack 11
12	OFF	OFF	ON	ON	Set to Pack 12
13	ON	OFF	ON	ON	Set to Pack 13
14	OFF	ON	ON	ON	Set to Pack 14
15	ON	ON	ON	ON	Set to Pack 15

6.3 Inverter Compatibility List

Inverter brand		Model	Battery Protocol Selection	Battery Modules
	Growatt	LV ALL	Pylon	15
	SRNE	LV ALL	Pylon	15
	Voltronic power	LV ALL	Pylon	15
	Goodwe	LV ALL	Pylon	15
	Deye	LV ALL	Pylon	15
	Luxpower	LV ALL	Pylon	15
	Megarevo	LV ALL	Pylon	15
	SAKO	LV ALL	Pylon	15
	Sorotec	LV ALL	Pylon	15
	SMK Solar	LV ALL	Pylon	15
	Inhenergy	LV ALL	Pylon	15
	MUST	LV ALL	Pylon	15
	SUNGROW	LV ALL	Pylon	15
	Afore	LV ALL	Pylon	15
	Solis	LV ALL	Pylon	15
	Felicity	LV ALL	Pylon	15
	Frecon	LV ALL	Pylon	15

6.4 Low Voltage Battery to inverter CAN Terminal Pin Out

LOW VOLTAGE INVERTER CAN /BMS				
	CAN TERMINAL	Inverter Terminal Type	Inverter SIDE (PIN Number)	Battery SIDE RJ45 (PIN Number)
RJ45	CAN- H	RJ45	4	4
	CAN- L		5	5
Goodwe	CAN- H	RJ45	4	4
	CAN- L		5	5
Deye	CAN- H	RJ45	4	4
	CAN- L		5	5

Luxpower	CAN- H	RJ45	4	4
	CAN- L		3	5
Megarevo	CAN- H	RJ45	4	4
	CAN- L		5	5
Sorotec	CAN- H	RJ45	3	4
	CAN- L		5	5
Inhenergy	CAN- H	RJ45	4	4
	CAN- L		5	5
MUST	CAN- H	RJ45	6	4
	CAN- L		5	5
SUNGROW	CAN- H	RJ45	4	4
	CAN- L		5	5
Afore	CAN- H	RJ45	4	4
	CAN- L		5	5
Felicity	CANL1	RJ45	7	5
	CANH1		8	4

6.5 Low Voltage Battery to inverter RS485 Terminal Pin Out

LOW VOLTAGE INVERTER RS485				
	RS485 TERMINAL	Inverter Terminal Type	Inverter SIDE (PIN Number)	Battery SIDE RJ45 (PIN Number)
RJ45	RS485-B	RJ45	1	1, 8
	RS485-A		2	2, 7
Growatt	RS485-B	RJ45	8	1, 8
	RS485-A		7	2, 7
SRNE	RS485-B	RJ45	3	1, 8
	RS485-A		5	2, 7
Voltronic power	RS485-B	RJ45	3	1, 8
	RS485-A		5	2, 7
SAKO	RS485-B	RJ45	3	1, 8
	RS485-A		5	2, 7
Frecon	RS485-B	RJ45	1	1, 8
	RS485-A		2	2, 7

SMK Solar	RS485-B	RJ45	1	1, 8
	RS485-A		2	2, 7
Solis	RS485-B	RJ45	1	1, 8
	RS485-A		2	2, 7

INFORMATION

Regarding the communication between the battery and the inverter, the battery side needs to maintain the original configuration, but inverters of different brands and models may have different communication pins. If in doubt, refer to the inverter manual.

7. Color touch screen instructions

1. Boot page

After power-on activation, the power-on interface will be displayed, as shown in the following figure:

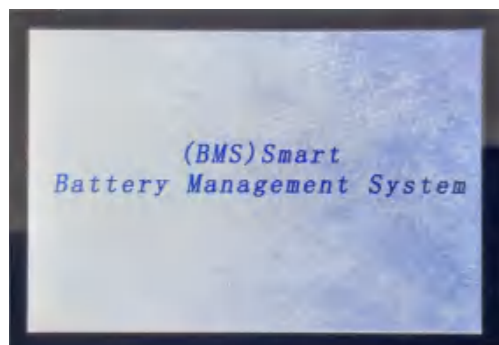

2. Main menu page

Touch anywhere on the screen to enter the main menu page, as shown in the following figure:



3. Battery parameter collection page

After touching "PACK-INFO" on the screen, you will enter the battery parameter collection page, as shown in the following figure:



4. Battery status page

After touching "STATUS" in the screen, you will enter the battery status page, as shown in the following figure:

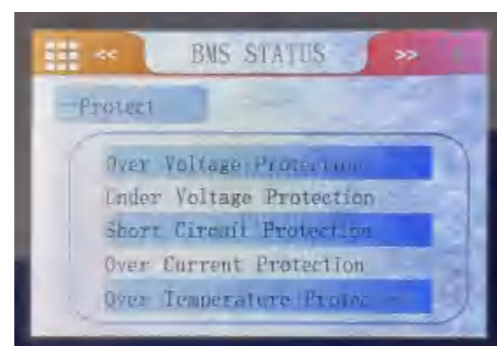

5. Battery protocol page

On this page, you can select the corresponding communication protocol as needed, as shown in the following figure:

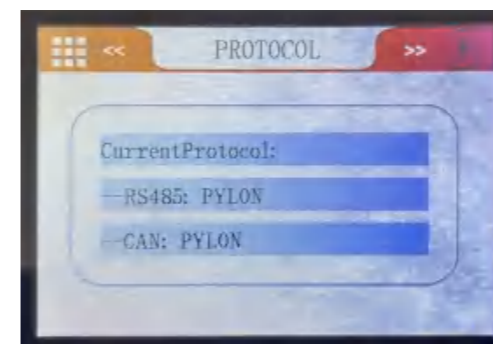

6. System page

On this page, you can view the "PACK-SN", the version number, and the setting language, as shown in the following figure:

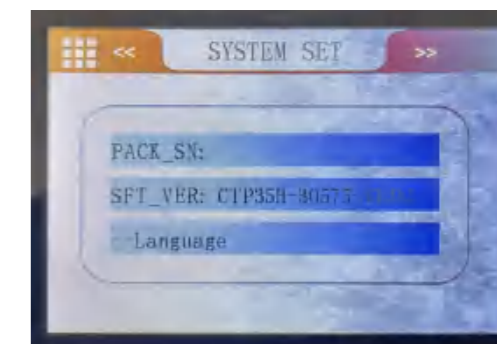

7. Key description

- (1) Each page can be accessed through >>, <<, or swipe up and down to operate the interface
- (2) "☐" Press the nine-square grid in the upper left corner to return to the main interface.
- (3) "🔋" Press the battery icon to go into the battery status.
- (4) In the dormant state, touch anywhere on the screen to activate the display.
- (5) The default password for the touch screen is: 123456, but it is not recommended for end users to modify the battery parameters at will.

8. Sleep/Shutdown

In normal operation, the system will enter the hibernation/shutdown state after 3 minutes of keyless operation.

In the shutdown/hibernate state, operate any button, the display will be activated and the main status interface will be entered.

9. All date of LCD display

◆ CTP28/35-1.1

› MIN STATE PAGE

WAIT for 5s,
show min state page

Total SOC

Current

Voltage

Warranty

› HOME

PACK Info

- Pack V
- Im
- Temperature
- cell voltage
- cell cap city

BMS Status

- Packs status
- Protect
- Warning
- Fault

SYSTEM

- PACK SN
- Language selection:
 - English
 - Chinese

PROTOCOL

- CAN
 - SO FAR PROTOCOL
 - Shouhang energy storage inverter BMS general CAN protocol V 2.1.00220191204
 - GOOD WE PROTOCOL
 - LV BMS Protocol(CAN) for Solar Inverter Family EN_V 1.5
 - PYLON PROTOCOL 2.0
 - Pylon CAN bus protocol V 2.0.420211122
 - SMA PROTOCOL
 - SMAF SS-Connecting Bat-TI-en-20W
 - GROW ATT_PROTOCOL
 - Grow at tBM SCAN-Bus-protocol-low-voltage-V 1.04
- RS485
 - USER_485_VOLTRON
 - Vol tronic Inverter and BMS 485 communication protocol 20200325(1)
 - USER 485PYLON
 - RS485-protocol-pylon-low-voltage - Added protocol design V 3.5
 - USER_485_LUX POWER
 - Lux power tek Battery Protocol RS 485_V 01

8. Technical parameter list

Model	ES25.6-100LP	ES25.6-230LP	ES51.2-100LP	ES51.2-230LP
Array Mode	8S	8S	16S	16S
Nominal Energy (KWh)	2.56	5.88	5.12	11.77
Nominal Voltage (V)	25.6	25.6	51.2	51.2
Charge Voltage (V)	29.2	29.2	58.4	58.4
Discharge Cut-off Voltage (V)	21	21	42	42
Standard Charging Current(A)	20	46	20	46
Max.Continuous Charging Current (A)	100	100	100	200
Max.Continuous Discharging Curent (A)	100	100	100	200
Communication Mode	RS232/RS485/CAN			
Cycle Life	≥6000 Times @80%DOD,25°C			
Operating Temp	Charging: 0~60°C; Discharging: -10°C~60°C			
Size(LxWxH) mm	440x170x350	440x170x560	440x170x560	450x245x670
Net Weight (Kg)	~23	~49	~41	~93
Package Size (LxWxH) mm	512x425x252	635x512x252	635x512x252	750x520x425
Gross Weight (Kg)	~25	~54	~54	~111

Note: The dimensions in the are the product appearance dimensions. If any change for the products, will adjusted by the manufacture.

9. Maintenance and conservation

Item	Problem description	Possible causes	Solution
1	The battery cannot be turned on normally, and there is no response when pressing the button.	1. The button is damaged or the button cable is disconnected; 2. BMS damaged; 3. The battery is seriously over-discharged.	1. Check whether the button is normal; 2. Check whether the voltage of the battery pack is normal; 3. If the voltage of the battery pack is too low, you need to use a constant current power supply or a lithium battery charger to charge the battery until the low voltage protection is released.
2	The BMS immediately enters the protection state after pressing the switch.	1. Battery pack voltage is abnormal; 2. Abnormal temperature; 3. External load mismatch.	1. Check whether the voltage of the battery pack itself is consistent; 2. Check whether the BMS voltage collection is abnormal; 3. Confirm whether the ambient temperature exceeds the BMS temperature preset value and whether the temperature probe is damaged; 4. Determine whether the load power and voltage match the battery.
3	Display screen does not display.	1. Display screen failure; 2. connection cable failure; 3. communication failure.	1. Press the power button to restart; 2. Check whether the display is damaged; 3. Check whether the cable is intact, whether there is any damage, disconnection, etc., and whether the connector is plugged in properly.
4	The communication fault occurs when the load is inverter	1. Communication line connection error (improper pin connection or poor contact); 2. Does not match the inverter communication protocol; 3. Communication mode do not match; 4. Correspondence address error; 5. Signal interference.	1. Check whether each pin of the communication line is broken; 2. Check whether the corresponding pins are connected correctly; 3. Check whether the contact part of the communication cable connection terminal is oxidized; 4. Confirm whether the inverter selects the matching protocol; 5. Confirm whether the correct communication method is selected, such as CAN and RS485 or other communication methods; 6. Confirm whether the inverter needs to select a communication address, and confirm whether the battery communication address is correct; 7. Confirm whether there are high-frequency interference sources in the battery usage scenario.
5	The output is suddenly disconnected during use	1. The battery voltage is too low, triggering BMS protection; 2. BMS protection caused by excessive load power or short circuit at the output end.	1. Check whether the battery voltage is within the normal range. If the voltage is low, charge the battery; 2. Adjust the load power to match; short circuit: disconnect the load or restart the battery.
6	SOC does not match actual value	1. SOC cumulative error during charging and discharging; 2. SOC is not calibrated; 3. The internal battery parameters of BMS have changed.	1. Calibrate the SOC, discharge to battery protection and then charge to 100% of the battery to complete the calibration; 2. After the parameters related to the internal battery capacity of the BMS change, the SOC needs to be re-estimated and a power calibration needs to be performed.
7	In order to protect your rights and interests, after you purchase our products, if you encounter problems with the installation and use of the product, you can contact the supplier, and we will provide you with after-sales service as soon as possible.		

In order to maintain the best and long-term performance, the following items are recommended to be inspected twice a year.

1. Confirm that the surrounding air flow will not be blocked, and remove any dirt and debris on the cooling hole.
2. Check all exposed wires, shabby and damage, please place or repair them if necessary.
3. If it is not used for a long time, it is recommended to charge it every three months.

Danger of electric shock! Make sure that the power supply has been disconnected during the above operations, and then carry out corresponding inspection and operation.

10. Warranty record card

Dear Customers:

Hello! Thank you very much for purchasing our products. In order to serve you better, please read and fill in and keep this warranty card after purchasing the product. In order to avoid your worries, our company here by makes a warranty service commitment and provides standardized after sales service accordingly.

Exemption of warranty liability scope:

1. Damage caused by man-made or other natural disasters.
2. Failure caused by incorrect operation and installation or use in an environment other than the product's prescribed use.
3. Damage caused by unauthorized disassembly and modification.

Contact: _____ Number: _____

Tel: _____ Email: _____

Purchase date: _____

Address: _____

Maintenance records			
Repair Date	Repair content	Repair Person	remark